

# Electrohydraulic Actuators

## Type 3274 – 11 to - 23



### Application

Actuators for positioning control valves.  
The electrohydraulic linear actuators receive three-point stepping or continuous-action output signals from electric controllers.  
**Nominal thrust up to 7300 N · Rated travels 15 and 30 mm**



The actuators are available with different thrusts.

Special features are:

- Compact design including electric, or optionally mechanical override.
- Safe functioning due to force-dependent disconnection of the motor when reaching final positions, or when overload occurs.
- Installation of positioner, potentiometers, and electric or inductive limit switches in the terminal box.
- Optionally, fail-safe position for version with electric override.

### Versions with electric override (Fig. 1)

Electric override activated using two push buttons on the terminal box

**Type 3274-11** · Electrohydraulic Actuator with nominal thrust  $F_{in}$  of 2100 N in operating direction "In", and nominal thrust  $F_{out}$  of 1800 N in operating direction "Out"

**Type 3274-12** ·  $F_{in}$  of 500 N and  $F_{out}$  of 3000 N

**Type 3274-13** ·  $F_{in}$  and  $F_{out}$  of 4300 N, respectively

**Type 3274-14** ·  $F_{in}$  of 500 N and  $F_{out}$  of 7300 N

### Versions with mechanical override (Fig. 2)

Mechanical override adjusted with an Allen key (width across flats/SW 24) at the additional gearing housing

**Type 3274-15** ·  $F_{in}$  of 2100 N and  $F_{out}$  of 1800 N

**Type 3274-16** ·  $F_{in}$  of 500 N and  $F_{out}$  of 3000 N

**Type 3274-17** ·  $F_{in}$  and  $F_{out}$  of 4300 N, respectively

**Type 3274-18** ·  $F_{in}$  of 500 N and  $F_{out}$  of 7300 N

**Versions with fail-safe position** and electric override, operating direction of the spring return mechanism according to Fig. 1

**Type 3274-21** ·  $F_{in}$  of 2100 N and  $F_{out}$  of 1800 N  
operating direction of fail-safe position: "Out"

**Type 3274-22** ·  $F_{in}$  of 1800 N and  $F_{out}$  of 2100 N  
operating direction of fail-safe position: "In"

**Type 3274-23** ·  $F_{in}$  of 500 N and  $F_{out}$  of 3000 N  
operating direction of fail-safe position: "Out"

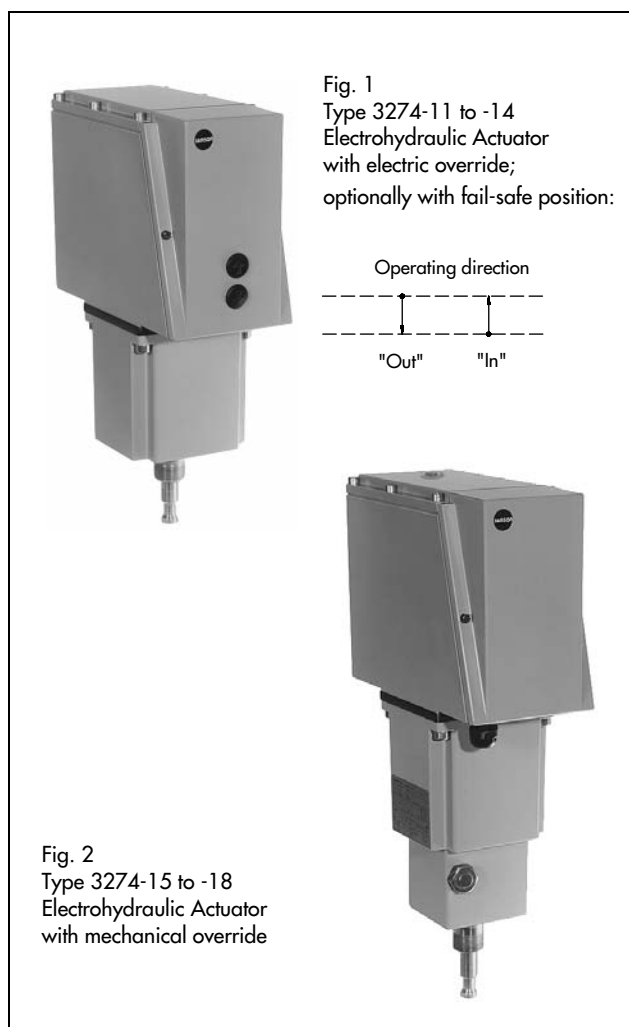

Fig. 2  
Type 3274-15 to -18  
Electrohydraulic Actuator  
with mechanical override

### Typetested versions

Type 3274-21 and Type 3274-23 Actuators with fail-safe position (operating direction "Out") have been typetested together with various SAMSON valves by German TÜV according to DIN 32 730. Register number available on request.

### Other certifications

- CSA for version 110 V/60 Hz
- NEMA 3

### Principle of operation (Fig. 3)

The pressure-tight actuator housing (1) also serves as oil reservoir and incorporates the cylinder housing (2), cylinder (5.1) and piston, motor (6.1), pump (6.2) and solenoid pilot valves (6.4). The required electric lines are oil-tight and pressure-tight and led from the terminal box (3) to the actuator housing.

The oil pump (6.2) driven by the motor (6.1) feeds compressed oil to the corresponding cylinder chamber via the check-valve (6.3) and pilot valve (6.4). Disconnected from current, the solenoid valves are closed. They open, when the controller issues a signal.

Depending on the version, the actuators are equipped with or without one or two compression springs (5.10, 5.11). These springs are used to reset the actuator, and they are part of the fail-safe position.

The motor is controlled by a relay in its electronics section and is directly connected to the power supply. Therefore, the contacts of the controller are subjected to a load of maximum two solenoid valves, and the electronics section of the motor is subjected to only minimum load.

When reaching final positions, or external forces cause the nominal force of the actuator to be exceeded, the force-dependent switches (4.3) or (4.4) deactivate the motor.

**CAUTION:** Do not open housing cover (1.1)!

The hydraulic equipment need not be maintained; oil change is not necessary.

**Versions with fail-safe position** have a spring return mechanism and an additional safety solenoid valve which opens when power supply is interrupted, thus reducing the pressure on the cylinder chamber. In this process, electric override is not possible.

### Manual override

The actuators possess an electric or optionally a mechanical override as standard.

Versions with fail-safe position are supplied with electric override only.

**Electric override** · There are two push buttons on the terminal box (3). Any travel position can be reached independent of the control signal.

After the push button is released, the actuator reacts again according to the controller signal. The control signal can be interrupted by opening the isolator terminal (81 in Figs. 4 to 6).

**Mechanical override** · The release button on the top side of the actuator housing must be activated. An Allen key (SW 24) can be used for adjustment. As soon as the release button is deactivated, the actuator reacts again according to the controller signal.

### Additional electrical equipment

The entire electrical equipment can be accessed in the terminal box (3). Table 2 shows the maximum amount of equipment.

The housing cover (1.1) is secured by special screws and must not be opened!

**Electric positioner** · The positioner compares the controller signal to the signal issued by a potentiometer. The potentiometer signal is proportional to the travel. The output variable produced by the positioner is a three-point stepping control signal.

Zero and span for normal and split-range operation are adjustable within broad limits.

The operating direction (increasing/increasing or increa-

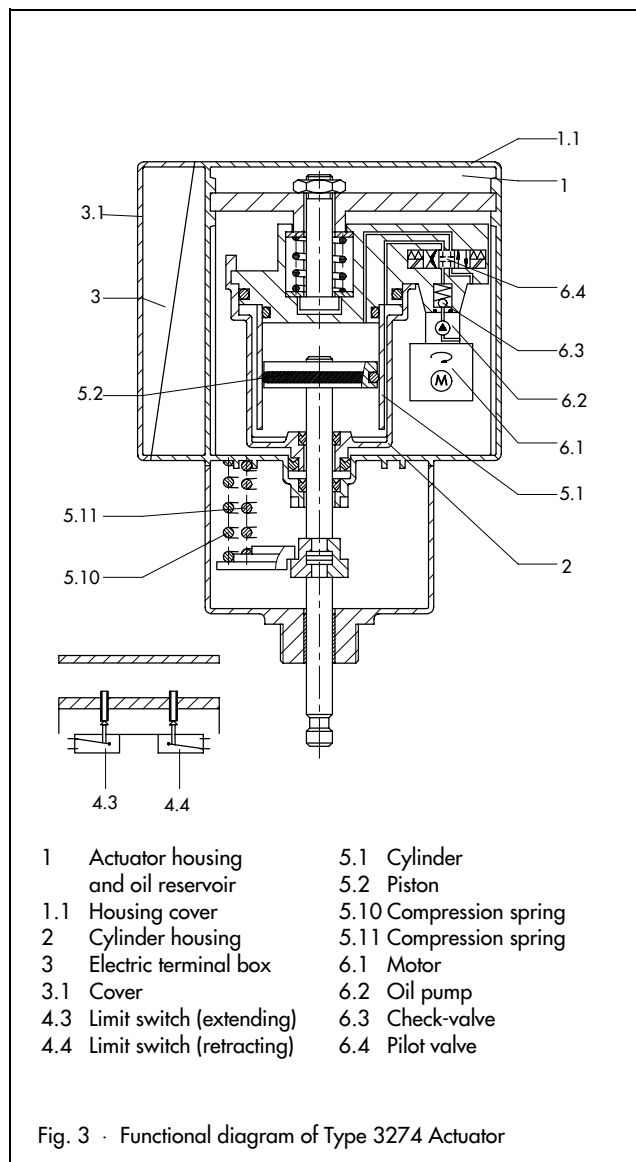

Fig. 3 · Functional diagram of Type 3274 Actuator

sing/decreasing) can be chosen. Via an external make contact, the final position "In" or "Out" can be reached. This does not affect the safety function. The positioner has an additional **output for valve position feedback**.

**Electric position transmitter** · Output signal 0(2) to 10 V or 0(4) to 20 mA with potentiometer 0 to 1000  $\Omega$  for versions with three-point stepping signal.

**Potentiometer** · Actuators can be equipped with one or two potentiometers. Versions with positioner require a potentiometer for valve position feedback to the positioner.

**Electric limit switch** · Actuators are equipped with maximum three overridable electric or inductive limit switches on request. The limit switches are activated via infinitely adjustable cam disks.

The transistor relays necessary for operation are not included in the delivery.

**Heating resistor** · Heating the hydraulic oil increases the lower temperature range. The heating resistor is not protected by the internal fuse. We recommend that an external fuse be used in accordance with the power consumption data indicated on the nameplate. Please also note the instructions for mounting positions in the Mounting and operating instructions EB 8340 EN.

**Table 1 · Technical data**

Actuator		Type 3274-	-11	-12	-13	-14	-15	-16	-17	-18	-21	-22	-23	
Version with manual override			Electric -				Mechanical -				Electric -			
Fail-safe position			Without								With			
Operating direction			"Out"	"In"	"Out"									
Rated travel			15 or 30 mm											
Nominal actuating time			60 s for 15 mm; 120 s for 30 mm (depending on temperature and required thrust · 1/2 actuating time on request)											
Speed of response for fail-safe action [mm/s]		Standard	-								1	1	1.3	
		Optional									4.3	4.3	5.6	
Thrust (N) at travel	15 mm Stem:	"In"	2100	500	4300	500	2100	500	4300	500	2100	1800	500	
		"Out"	2000	3400	4300	7700	2000	3400	4300	7700	2000	2300	3400	
	30 mm Stem:	"In"	2100	500	4300	500	2100	500	4300	500	2100	1800	500	
		"Out"	1800	3000	4300	7300	1800	3000	4300	7300	1800	2100	3000	
Electrical connection			230 V, 110 V, 24 V; 50 or 60 Hz (±10 % resp.)											
Power consumption			90 to 200 VA (maximum in version with 1/2 actuating time and heating)											
Permissible ambient temperature			-10 °C to +60 °C Wider range (with heating resistor): -35 °C to +60 °C											
Permissible storage temperature			-25 °C to +70 °C											
Degree of protection			IP 65											
Control operation			Duty cycling S4 according to VDE 0530/IEC 34 with 50% on-time											
Electronics section of motor			Radio interference level according to DIN VDE 0875											
Mounting			Central attachment M 30 x 1.5 · Special version for Type 3214 Valve, DN 150 to 250											
Weight		approx. kg	12				15				12			
<b>Additional electrical equipment</b>														
Electric positioner	Power supply		230 V, 110 V, 24 V; 50 or 60 Hz (±10 % resp.)											
	Control signal		4 to 20 mA, 0 to 20 mA (R <sub>i</sub> = 50 Ω) · 0 to 10 V, 2 to 10 V (R <sub>i</sub> = 10 kΩ)											
	Zero shift		0 to 100 %											
	Change of span		30 to 100 %											
	Output (feedback)		4(0) to 20 mA, R ≤ 200 Ω · 0(2) to 10 V, R ≥ 2 kΩ											
Potentiometer (additional ranges on request)			0 to 1000 Ω; 0 to 200 Ω; 0 to 100 Ω; 0 to 275 Ω; 0 to 138 Ω (when rated travel is 80 % of final value); permissible load 0.5 W											
Electric limit switch			Maximum three separately adjustable limit switches (see Table 2)											
Permissible load			250 V~, 5 A											
Inductive limit switch			Proximity switch SJ 2-N											
Control circuit			Values according to downstream transistor relay (not included in delivery)											
Heating resistor, approx. 45 W			With thermostat, "on" at approx. -10 °C, "off" at approx. 0 °C											

**Table 2 Additional electrical equipment**

Additional equipment	Max. equipment combination (arranged by columns)							
Electric positioner	•	•	-	-	-	-	-	-
Electric positioner	-	-	•	•	-	-	-	-
Potentiometer 1	1000 Ω <sup>1)</sup>	1000 Ω <sup>1)</sup>	1000 Ω <sup>1)</sup>	1000 Ω <sup>1)</sup>	•	•	-	-
Potentiometer 2	•	•	•	•	•	•	-	-
Electric limit switch 1	-	-	-	-	-	-	•	•
Electric limit switch 2	•	-	•	-	•	-	•	-
Electric limit switch 3	•	-	•	-	•	-	•	-
Inductive limit switch 1	-	•	-	•	-	•	-	•
Inductive limit switch 2	-	•	-	•	-	•	-	•

<sup>1)</sup> Required for position transmission to the positioner

**Table 3 · Materials**

Housing and housing cover	Die-cast aluminum, plastic-coated
Cylinder	Hydraulic cylinder tube
Piston	Steel-NBR combination
Piston stem	C45, chromium-plated
Actuator stem	WN 1.4104
Hydraulic oil	Special HLP, silicone-free

**Electrical connection (Figs. 4 and 5)**

Figs. 4 and 5 schematically illustrate the different means of connection, depending on how the respective version is equipped. The electric limit switches are provided with screwed connections. They are connected directly, not via the terminal block.

Especially for 24 V actuators, lines of sufficient cross-section must be laid in order to guarantee that the permissible voltage tolerances of  $\pm 10\%$  are kept.

The heating resistor is connected without additional terminals to L and N in the circuit.

**Connections**

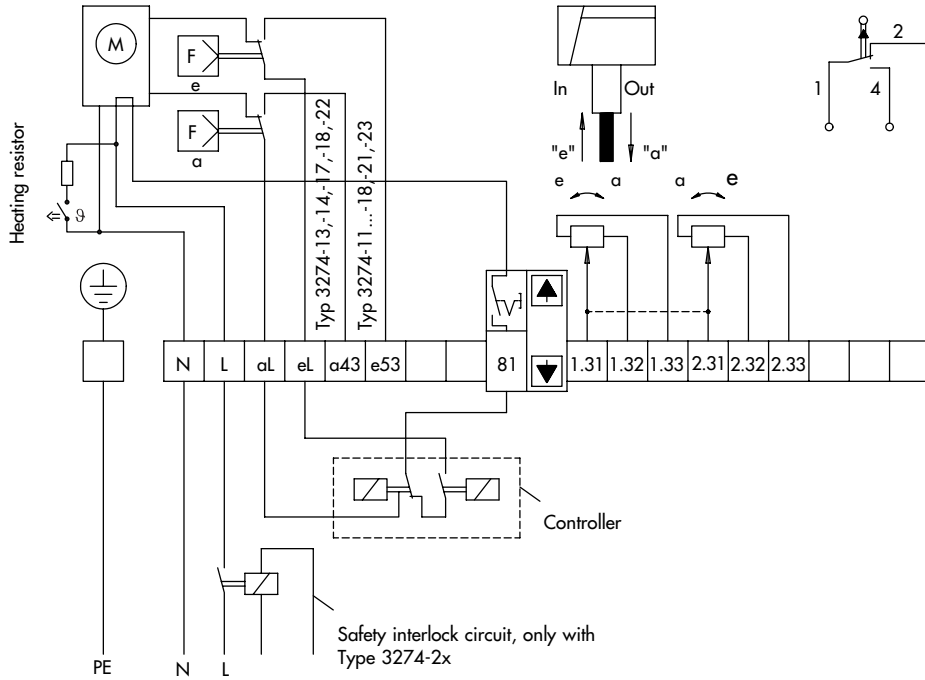

Fig. 4 · Circuit diagram for actuators without positioner

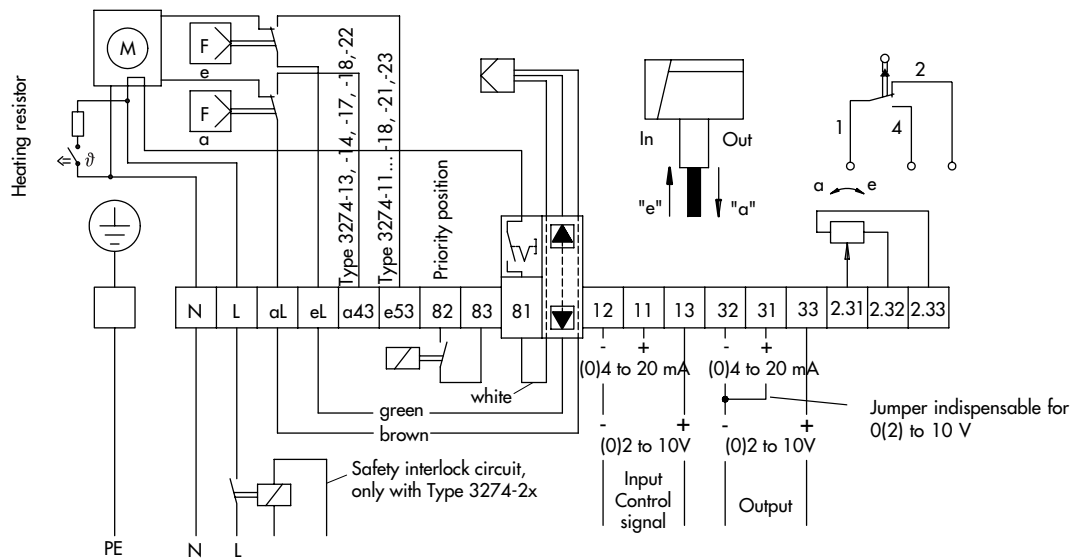

Fig. 5 · Circuit diagram for actuators with positioner

## Connections

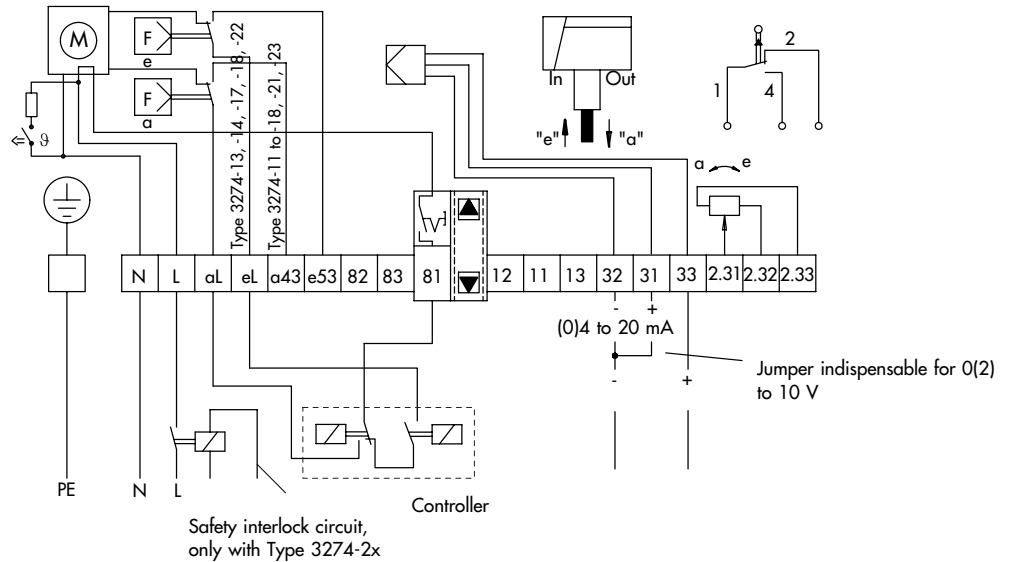
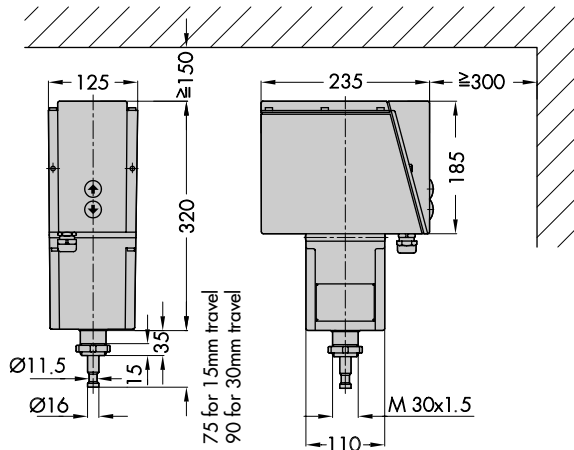
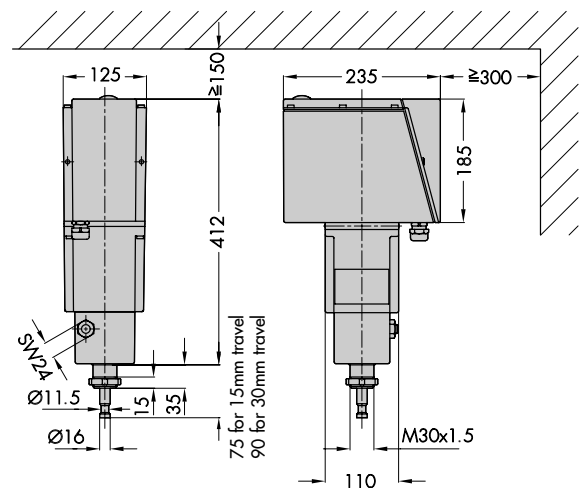

Fig. 6 · Circuit diagram for actuators with position transmitter

## Dimensions in mm



Type 3274-... Actuator with electric override



Type 3274-... Actuator with mechanical override

## Ordering text

Type 3274- ... Electrohydraulic Actuator  
 Rated travel 15/30 mm  
 Fail-safe position (only available with electric override)  
 Operating direction "In" or "Out"  
 Electrical connection 230/110/24 V; 50/60 Hz  
 Version for Type 3214 Valves, DN 150 to 250, if needed.

## Additional electrical equipment (see Table 2)

Positioner  
 Input signal 0(2) to 10 V / 0(4) to 20 mA  
 Position transmitter 0(2) to 10 V / 0(4) to 20 mA  
 Potentiometer 0 to 1000 Ω  
 0 to ... Ω  
 Limit switch electric/inductive  
 Heating resistor for wider temperature range

Specifications subject to change without notice.



SAMSON AG · MESS- UND REGELTECHNIK  
Weismüllerstraße 3 · 60314 Frankfurt · Germany  
Phone +49 69 4009-0 · Fax +49 69 4009-1507  
Internet: <http://www.samson.de>

**T 8340 EN**